

# Fire Prevention and Community Risk Reduction Division

A Guidebook for Contractor's for permit application  
Submittals, reviews, and inspections.



This is not an all-inclusive list of requirements; this shall serve as a general guide. All projects must be in accordance with the Poudre Fire Authority adopted fire code and all adopted amendments per City of Ft Collins, Town of Timnath, Larimer County and Weld County.



POUDRE FIRE AUTHORITY  
102 Remington St. Fort Collins, CO 80524 970.416.2891 [www.poudre-fire.org](http://www.poudre-fire.org)

## Table of Contents

Adopted Fire Code & Amendments .....	3
Requirements During Construction .....	3
Fire Apparatus Access Roads .....	3
Submittal Requirements .....	3
Premises Identification.....	4
Fire Lane Requirements .....	4
Knox Box Requirements.....	4
Apparatus Turning Dimensions.....	5
Aerial Fire Apparatus Access Roads .....	6
Minimum Contractor Qualifications .....	7
Fire Sprinkler Requirements .....	7
Fire Alarm Requirements.....	8
Kitchen Hood Requirements.....	9
ERCES Requirements.....	9
Gas Detection Requirements.....	10
Solar Photovoltaic Power Systems Requirements .....	10
Paint Booth Requirements.....	10
Tank Installation and Removal UST, AST, Generator, Chemical and Hazardous Material Requirements .....	10
Smoke Control Systems .....	11
Fees .....	11
APPENDIX A.....	12
Plan Review Requirements .....	12

## Adopted Fire Code & Amendments

The 2024 International Fire Code (IFC), as amended, is the current adopted fire code for the Poudre Fire Authority. In addition, the National Fire Protection Associate (NFPA) references as well as other codes/standards listed in Chapter 80 are adopted as part of the Poudre Fire Authority (PFA) fire code. The use of more current codes/standards, such as NFPA, may be accepted; provided it is requested in advance.

Currently adopted fire codes can be reviewed for City of Fort Collins, Town of Timnath, Larimer County, and Weld County [PFA Adopted Codes](#) Please review to the city, town, or county for adopted International Building Code (IBC) or International Residential Code (IRC).

## Requirements During Construction

**Access** – Fire Department vehicle access shall be provided by permanent or temporary roads capable of supporting vehicle loading (40 Tons) under all weather conditions.

**Water Supply** – An approved water supply for fire protection shall be available when combustible materials arrive on the site.

**Premises Identification** – A temporary address sign shall be maintained during construction for emergency responders.

## Fire Apparatus Access Roads

**Where required** – Fire apparatus access roads shall be provided and maintained in accordance with Sections 503.1.1 through 503.1.3 and Appendix D Fire Apparatus Access Roads.

**Dimensions** – Fire apparatus access roads shall have an unobstructed width of not less than 20 feet (6096 mm), exclusive of shoulders, except for approved security gates in accordance with Section 503.6, and an unobstructed vertical clearance of not less than 14 feet (4267 mm).

**Turning radius** – The required turning radius of a fire apparatus access road shall be 25 feet (7.6 m) inside radius and 50 feet (15.2 m) outside radius.

**Access and loading** – Facilities, buildings, or portions of buildings hereafter constructed shall be accessible to fire department apparatus by way of an approved fire apparatus access road with an asphalt, concrete, or other approved driving surface capable of supporting the imposed load of fire apparatus weighing at least 80,000 pounds (36,287 kg).

## Submittal Requirements

### See Appendix A

The following outlines the submittal requirements for all construction, operational, occupancy load submittal.

**Plan Review Turnaround Time** – PFA's goal is to provide a dependable, reasonable, and consistent plan review time frame for all submittals. Anticipate the plan review to require 4 weeks; depending on size and scope of project, times may vary. This targeted review time only applies to the initial review; subsequent reviews of resubmittals or of responses to the initial review comments generally require additional time. This is only a goal and not a guarantee; larger or more complicated projects or multiple same day tenant finish plan submittals may take longer.

Scope of Work reviews are 1 week

Underground fire lines are 2 weeks

**Request for alternative means and methods** – Shall be formally requested using PFA's AMM Request form.

**Inspection Requests** – For field inspection and testing related to plan review [Construction Inspection Request](#) Note, inspection requests are based upon personnel availability and when a request is sent, you will receive an

Outlook Calendar invite to confirm a date and time of inspection. Contractors are encouraged to plan ahead and communicate issues that arise that may dictate postponing inspections or testing. If an inspection is scheduled and personnel arrives, and the contractor is not ready a re-inspection fee will be imposed prior to scheduling the next inspection.

### Premises Identification

New and existing buildings or facilities shall be provided with approved premises identification. The premises identification shall be legible and placed in a position that is visible from the street or road fronting the property. Address identification characters shall contrast with their background. Address numbers shall be Arabic numbers or alphabetical letters. Numbers shall not be spelled out.

Address assignment and standards. Addresses shall be assigned by the governmental entity having jurisdiction (Fort Collins, Timnath, Larimer County, or Weld County) and shall comply with the Larimer County Street Naming and Addressing Standards as contained in the Larimer County Urban Area Street Standards. **See code amendments for details.**

### Fire Lane Requirements

During the plan review process indicate location and type of fire lane signs, a field inspection will be required.

#### Approved Signs

Sign Type "A"



Sign Type "C"



Sign Type "D"



- 18-inch-high x 12-inch-wide sign
- Reflective white background material.
- "Fire Lane" to be a minimum of 1-inch x ¼ inch stroke.
- Left or right arrows as required by specific site.

### Knox Box Requirements

Key Boxes are required to be installed per IFC 2024 Section 506. Boxes are required where immediate access to/within a structure/area is restricted because of secured openings. All buildings with a monitored life safety system must have a key box. Key box locations shall be provided on plans and cannot be installed until approved by PFA. Depending on the size and layout of the building, multiple boxes may be required.

Use this website to purchase a key box: [www.knoxbox.com](http://www.knoxbox.com). Confirm in upper left corner "**Poudre Fire Authority**" is listed. Click "Buy" and then choose the product you are purchasing, options include KnoxBox® 3200 for a maximum of 4 keys or KnoxVault® 4400 for maximum capacity. KnoxBox® location is at the main entrance or riser room entry. Place no higher than six (6) feet, area should be clear and unobstructed and must be visible from the street.

All new or existing Key boxes must contain the following keys as they apply to the building:

- Exterior master
- Riser room
- Fire panel
- Elevator key if equipped with an elevator

The number of floors and square footage of structures determines the number of sets of keys needed. This information also helps determine the size of the Knox Box and if more than one Knox Box will be required.

Each set will be placed on their own key ring.

- Single story buildings must have one of each key
- Two-three story buildings must have two of each key
- Four story buildings must have three of each key

Key tags for each key will be required and will be initially installed and maintained by the Fire Prevention Community Risk Reduction (FPCRR) Division.

- Master key – Green
- Riser room – Blue
- Fire panel – Red
- Optional Additional Keys and/or Key Box – White.

Additional keys can be placed in the Knox Box but must not inhibit the use of the Knox Box. If at any time a tenant needs to replace or update keys in his/her Knox Box, they must make the request using the electronic form on the PFA website.



KnoxBox® 3200  
Standard Capacity ⓘ



KnoxVault® 4400  
Maximum Capacity ⓘ

## Apparatus Turning Dimensions

The following dimensions are based upon a 100' aerial platform. All required fire apparatus access road designs within a development shall be able to accommodate the dimensions detailed below.

### Definitions

**Inside Cramp Angle:** Maximum turning angle of the front inside tire.

**Axle Track:** King-pin to king-pin distance of the front axle.

**Wheel Offset:** Offset from the center-line of the wheel to the king-pin.

**Tread Width:** Width of the tire tread.

**Chassis Overhang:** Distance from the center-line of the front axle to the front edge of the cab. This does not include the bumper depth.

**Additional Bumper Depth:** Depth that the bumper assembly adds to the front overhang.

**Wheelbase:** Distance between the center lines of the vehicle's front and rear axles.

**Inside Turning Radius:** Radius of the smallest circle around which the vehicle can turn.

**Curb to Curb Turning Radius:** Radius of the smallest circle inside of which the vehicle's tires can turn. This measurement assumes a curb height of 9 inches.

**Wall to Wall Turning Radius:** Radius of the smallest circle inside of which the entire vehicle can turn. This measurement takes into account any front overhang due to the chassis, bumper extensions and/or aerial devices.

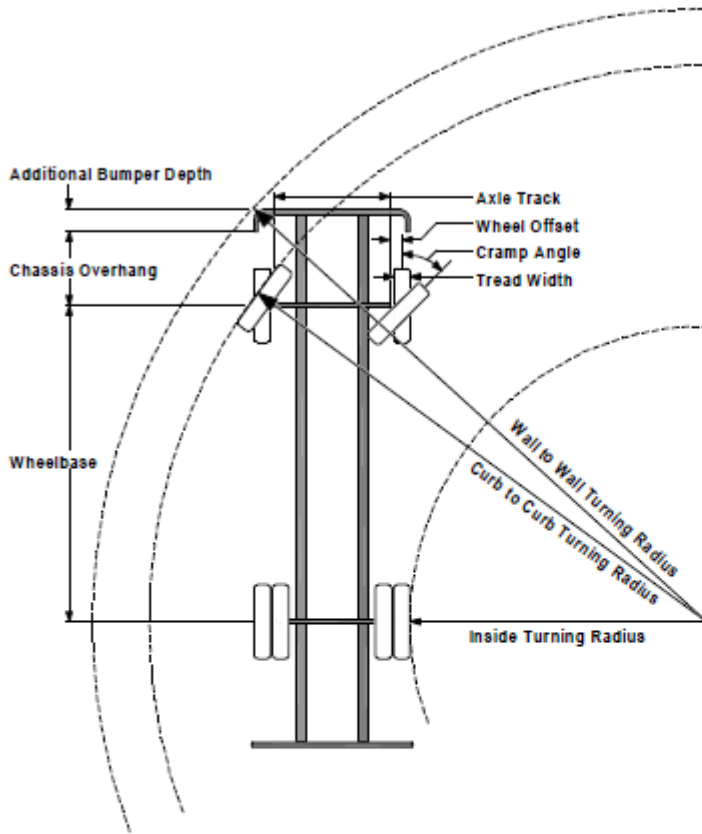

Parameters:	
Inside Cramp Angle:	40.00 °
Axle Track:	82.92 in.
Wheel Offset:	5.30 in.
Tread Width:	13.50 in.
Chassis Overhang:	78.00 in.
Additional Bumper Depth:	26.00 in.
Front Overhang:	160.60 in.
Wheelbase:	257.00 in.

Calculated Turning Radii:	
Inside Turn:	24 ft. 6 in.
Curb to Curb:	39 ft. 10 in.
Wall to Wall:	48 ft. 3 in.

**Comments:**  
 Aerial Application  
 Truck 21556

Components	PRIDE #	Description
Front Axle	0508846	Axle, Front, Oshkosh TAK-4, Non Drive, 24,000 lb, Velocity
Front Wheels	0019618	Wheels, Frt, Alum, Alcoa, 22.50" x 13.00" (425/445)
Front Tires	0038270	Tires, Goodyear, 445/65R22.50 20 ply G286 SS (24K "IS")
Chassis	0508407	Velocity Chassis (Big Block)
Front Bumper	0123627	Bumper, 26" extended, Imp/Vel
Aerial Device	0022160	Aerial, 100' Pierce Platform

**Notes:**

Actual Inside Cramp Angle may be less due to highly specialized options.

Curb to Curb turning radius calculated for a 9.00 inch curb.

### Aerial Fire Apparatus Access Roads

**Where required** – Where the vertical distance between the grade plane and the highest roof surface exceeds 30 feet (9,144 mm), approved aerial fire apparatus access roads shall be provided. For purposes of this section, the highest roof surface shall be determined by measurement to the eave of a pitched roof, the intersection of the roof to the exterior wall, or the top of parapet walls, whichever is greater.

**Width** – Aerial fire apparatus access roads shall have a minimum unobstructed width of 26 feet (7925 mm), exclusive of shoulders, in the immediate vicinity of the building or portion thereof if the fire apparatus access road is not a dead end. Dead end fire apparatus access roads for aerial apparatus access shall be a minimum of 30 feet (9144 mm) wide.

**Proximity to building** – One or more of the required access routes meeting this condition shall be located within a minimum of 15 feet (4572 mm) and a maximum of 30 feet (9144 mm) from the building and shall be positioned parallel to one entire side of the building. The side of the building on which the aerial fire apparatus access road is positioned shall be approved by the fire code official.

**Obstructions** – Overhead utility and power lines shall not be located over the aerial fire apparatus access road or between the aerial fire apparatus road and the building, other obstructions may be permitted to be placed only if approved by the fire code official.

**Grade** – Aerial fire apparatus access roads adjacent to the building shall not exceed five percent in grade.

**Road type** – Aerial fire apparatus access roads shall not be located on an arterial street with six or more through lanes as defined by the LCUASS standards for arterials.

### Minimum Contractor Qualifications

**See Guide for Minimum Contractor Qualifications for the following:**

Fire Alarm & Detection Systems

Fire Sprinkler Systems

Underground Fire lines & Fire Hydrants

Emergency Responder Communication Enhancement Systems

Commercial Cooking Equipment & Extinguishing Systems

### Fire Sprinkler Requirements

All fire sprinkler system designs, installations and inspections shall comply with Colorado Division of Fire Prevention & Control's Fire Suppression Program 8 CCR 1507-11; it is solely the responsibility of the fire sprinkler contractor to provide PFA documentation that meets all CO laws and regulations and PFA adopted codes, standards and local ordinances. Fire sprinkler systems shall be designed by a NICET III or higher; designed and installed per all applicable codes, standards and equipment manufacturer's instructions. A full submittal will be required for projects where the cumulative scope of work impacts more than (20) sprinkler heads within a 180-Day period. Flow tests must be conducted within the last year from the date the hydraulic calculations.

**Scope of Work** – To provide a more streamlined plan review process, the Poudre Fire Authority allows the submission of a scope of work letter in lieu of providing full shop drawings for modifications to existing fire sprinkler systems that meet the criteria noted below in full. It is the responsibility of the submitting contractor to review the following information.

**THE SCOPE OF WORK LETTER PROCESS IS NOT INTENDED TO BE USED FOR MULTIPLE SMALL PROJECTS THAT ARE SUBSTITUTE FOR A FULL SUBMITTAL. A FULL SUBMITTAL WILL BE REQUIRED FOR PROJECTS WHERE THE CUMULATIVE SCOPE OF WORK IMPACTS MORE THAN (20) SPRINKLER HEADS.**

**Underground Requirements** – Fire suppression underground applications shall be submitted by a Colorado certified fire suppression - underground contractor. Certificates and material cut sheets shall be provided at initial submission. Plan set drawings are required to reflect piping from main to flange to riser assembly. Designs and installation shall follow the requirements listed in NFPA 24. Required inspections include bedding and/or thrust blocks, hydrostatic testing, and debris/super flush to be witnessed by PFA. A NFPA 24 "Materials & Test Certificate" for fire suppression underground piping shall be provided prior to final inspection

**Standpipe Requirements** – Standpipes shall be designed, installed and tested in accordance with all CO laws and regulations and PFA codes, standards and local ordinances. In addition to roughs/hydrostatics, flow testing shall be conducted by the suppression contractor and witnessed by the fire code official, in accordance with NFPA 14 requirements. A NFPA 14 "Materials & Test Certificate" shall be provided prior to final inspection.

\*PFA's Pumper Information: 1500gpm at 150psi. PFA would require the design to determine if a fire pump is required without utilizing augmented pressure from any apparatus.

**FDC** – The location of the FDC is to be proposed during the plan review process. PFA will determine whether the location indicated on submitted plans is adequate. Some situations will require locating the FDC in the field.

- **Size & Type-** Hose threads are required to be compatible with PFA operational procedures and be sized according to system demand excluding exterior hose stream allowances as per the following:
  - (1) – 2-1/2" inlet for systems under 250 gpm
  - (2) – 2-1/2" inlets (Siamese) for systems above 250 gpm and under 500 gpm.
  - (1) Angled 5" Storz-type connector for system demands of 500 gpm or greater.
  - (1) Angled 5" Storz-type connector for FDC's serving standpipes.

**Residential Sprinklers** – Prior to submitting plans to PFA confirm with Building Division on whether sprinklers are required. All standalone 13D systems are a deferred submittal through PFA, and multipurpose/P2904 systems will be reviewed through the Building Division.

**Inspection Requirements** – The stamped reviewed plans and permit certificate must always remain on-site; inspection will not be conducted if these documents are not on-site. Inspections must be requested via PFA website 48 hours prior to requested time.

Rough inspection and hydro testing required on most jobs prior to final. Final inspection shall be requested by General Contractor and coordinated with subcontractors to be present. Projects shall have rough/hydro when required. Sprinkler piping shall be visible for the inspector. At the time of final inspection, completed backflow certifications, underground and aboveground "Materials & Test Certificat" shall be given to the inspector. All flow and tamper switches must be wired to the fire alarm control panel and operational at the time of final inspection. The contractor must provide all necessary testing equipment and perform all testing required by the inspector.

### Fire Alarm Requirements

Fire Alarm systems shall be designed, installed, and tested to all applicable codes, NFPA standards, and manufacturer's instructions. Plans shall be designed and stamped by a fire alarm contractor who is NICET III minimum certified, fire protection engineer and/or factory authorized by the fire alarm panel manufacturer for the system present in the building. Fire alarm scope of work letter is acceptable in some cases.

**Scope of Work** – To provide a more streamlined plan review process, Poudre Fire Authority allows the submission of a scope of work letter in lieu of providing full shop drawings for modifications to existing fire alarm systems that meet the criteria noted below in full. It is the responsibility of the submitting contractor to review the following information.

A scope of work letter is encouraged to be used for the replacement of any communicator (dialer swap) as well as the modification or replacement of a fire alarm control unit (FACU), so long as no other system modifications are being completed. For example, system modification to voice EVAC, or from a conventional to an addressable system would not be eligible for a scope of work submission.

**Horn/Strobe Requirements** – Clear lens horn/strobe: activate on water flow, at the location of FDC

**Remote Annunciator** – Remote annunciators shall be installed on fire alarm systems where the Fire Alarm Control Panel (FACP) is not in a readily accessible location for responding personnel. The annunciators shall be located during the plan review phase; typically, this will be located at the main point of entry for the building. Depending on the size of the building, more than one (1) annunciator shall be installed.

**Graphic Map** – A permanently mounted graphic map must be located adjacent to either the FACU or the remote annunciator. All fire alarm initiating devices shall be shown on the map, name and address with unit numbers of the building. Graphic maps shall be updated to reflect changes in new projects and shall be replaced if deemed illegible. The graphic map shall be noted on each fire alarm plan, including tenant modifications. This map shall be mounted in such a way that it will be sturdy and not be damaged during normal business operations.

**Inspection Requirements** – The stamped plans and permit certificate must always remain on-site; inspections will not be conducted if these documents are not on-site. Inspections must be requested via PFA website 48 hours prior to requested time.

Currently PFA does not inspect rough wire. Final inspection shall be requested by General Contractor and coordinated with subcontractors to be present. Prior to final inspection, the system shall be 100% tested and monitored on-line for 12 continuous hours. NFPA 72 Record of Completion shall be provided to PFA during final inspection. During the final inspection for new systems, panels and dialers shall not be called offline until it has been verified that the supervisory station reports an alarm to dispatch.

### **Kitchen Hood Requirements**

Fire suppression systems are required on all Type I Kitchen Hoods. Kitchen hood suppression systems shall be designed and installed per fire code and all applicable NFPA codes. These submittals shall include, but not limited to, nozzle location, nozzle distance from appliance, size of suppressant required, indicate appliances being protected, Class K fire extinguisher location and manual pull station location. All hood and duct / mechanical installation and modification is reviewed and inspected by the City, Town, or County.

**Scope of Work** – To provide a more streamlined plan review process, Poudre Fire Authority allows the submission of a scope of work letter in lieu of providing full shop drawings for modifications to existing commercial cooking systems with Type I hoods that meet the criteria noted below in full. It is the responsibility of the submitting contractor to review the following information.

**THE SCOPE OF WORK LETTER PROCESS IS NOT INTENDED TO BE USED FOR MULTIPLE SMALL PROJECTS AS A SUBSTITUTE FOR A FULL SUBMITTAL. A FULL SUBMITTAL WILL BE REQUIRED FOR PROJECTS WHERE THE CUMULATIVE SCOPE OF WORK INCLUDES MODIFICATIONS TO MORE THAN (2) APPLIANCES AND FOR THE CONDITIONS NOTED BELOW.**

**Inspection Requirements** – The stamped plans and permit certificate must always remain on-site; inspection will not be conducted if these documents are not on-site. Inspections must be emailed 48 hours prior to requested time. During inspection the following will be tested for proper operation: manual pull station, fusible link, deactivation of fuel sources under the hood, deactivation of “make-up air”, activation of fire alarm, and proper location of the Class K extinguisher (Hood must be fully functional to receive final sign-off). You will be required to mark appliance’s location with permanent marker/chalk to assure appliances are placed in exact location after they are moved for cleaning.

### **ERCES Requirements**

**Responsibility** – New construction or tenant finish review letter will specify the necessity to survey the building for ERCES. Survey shall be emailed to [plans@poudre-fire.org](mailto:plans@poudre-fire.org) pass or fail.

Poudre Fire Authority (AHJ) shall issue permits for the installation of ERCES and Larimer County or State of Colorado FCC License Holder (FLH) shall verify compliance with this regulation. Federal compliance - ERCES installation, components, and operation, shall comply with all applicable Federal regulations, including but not limited to, the Federal Communications Rules specified in Title 47 of the Code of Federal Regulations, including 47CFR §90.219. Amplification systems capable of operating on frequencies licensed to any public safety agency by the FCC shall not be installed without prior coordination and express written consent of the FLH.

**Retransmission Authorization form MUST be submitted with permit application**

**Minimum Contractor Qualifications** – In-Building Public Safety Communications (IB-PSC) Certification from the National Institute for Certification in Engineering Technologies’ (NICET). Design Performance certification required for the design layout, stamped and at least a level II for installation.

**Inspection Requirements** – When the system has been installed, pretested and is ready for final inspections, the permit holder must contact the PFA to schedule the final acceptance test. The system shall be tested in accordance with the requirements of NFPA 1225.

### **Gas Detection Requirements**

Gas detection systems required by this code shall comply with Sections 916.2 through 916.11. Documentation of the gas detection system design and equipment to be used that demonstrates compliance with the requirements of this code shall be provided with the application for permit. Compressed gases – carbon dioxide enrichment systems (Section 5307.4) and insulated carbon dioxide beverage dispensing (Section 5307.3)

Carbon dioxide beverage dispensing systems that have been issued an approved construction permit are also required to obtain an annual operational permit. Operational permits shall be the responsibility of the property owner or operator of the system to obtain. Operational permits shall be obtained within 12 months from the approval of your construction permit and annually thereafter. Operational permits ensure that systems are properly maintained in accordance with requirements of the adopted Fire Code. Please find a link on our website to PFA's Operational Guidebook and the operational permit application process here: [PFA Operational Permit Carbon Dioxide](#)

### **Solar Photovoltaic Power Systems Requirements**

Solar photovoltaic (PV) systems shall be installed in accordance with the IBC or IRC. The electrical portion of solar PV systems shall be installed in accordance with NFPA 70. Rooftop-mounted solar photovoltaic systems shall be installed in accordance with Sections 1205.2 through 1205.4.3. Ground-mounted solar photovoltaic systems shall comply with Section 1205.5.

### **Paint Booth Requirements**

New construction permit is required for the review of a new spray booth installation. Spray booths installed shall 3 feet clear space on all sides of the booth. Floors shall be of non-combustible material or covered by an approved, non-combustible, non-sparking material. Spray booth walls shall have smooth interior face and penetrations shall be sealed with fire resistant caulk. Proper shutdown, interlocks, ventilation, and electrical requirements shall be submitted for review. Permit application shall include information regarding hazardous material used, Colorado Professional Engineer stamped or pre-engineered system plans, and material data sheets for all components. Design requirements shall meet the respective NFPA standards and IFC requirements.

Separate delayed/deferred submittal for fire protections systems is required. Flammable finish spray operations per IFC 2404.4 shall have suppression systems installed prior to use (Section 903 or 904).

### **Tank Installation and Removal UST, AST, Generator, Chemical and Hazardous Material Requirements**

**Installation** – A PFA permit to install or remove any fuel storage tank is required prior to the start of the job. A Colorado Division of Oil and Public Safety (OPS) permit is also required for any amount over 660 gallons and must be included with the permit application. Plan set must include site plan indicating location of tank to property lines and buildings. Type of fuel and amount with tank specifications. Provide proper signage, markings, and identification, including 704 Placard. Provide vehicle protection where needed and fire extinguisher(s). Provide required spill control, avoid sources of ignition, including combustible waste and vegetation.

**Inspection Requirements** – A copy of the signed- off OPS permit shall be provided to the PFA after all final inspections. Inspection of venting, connections, remote shutoff, dispensing devices, emergency disconnect switches, operation instructions, emergency procedures, and protection from damage.

**Removal** – Provide proper safe work preparation. All product or connecting lines shall be drained back into tank. Remove all flammable or combustible liquid and residue from the tank, tanks shall be purged of vapor and inerted prior to removal and tanks shall be tested and deemed safe to move when an LFL reading of 10 to 20% is achieved as measured by a combustible gas indicator or when an oxygen meter reads a range of 1 to 10 percent oxygen concentration. During removal, the tanks shall be secured, and then safely and completely lifted onto the transport vehicle, tanks shall not be dragged.

**Hazardous Materials** – Plan set should include site plan indicating location to building, foundation requirements, and SDS sheets. Provide tank specifications, manufacture cut sheets. Provide appropriate markings, NFPA 704 Placard, ASME A13.1, and emergency shutoff valves. Piping system for ventilation shall comply with adopted IFC and manufacture specifications. Provide security from tampering, fencing, enclosure, and vehicle impact protection.

### Smoke Control Systems

Smoke control systems shall be installed, inspected, and maintained in accordance with IBC & IFC Section 909 and any methods deemed acceptable to PFA. IFC Section 909.2 states that systems shall be designed in accordance with “generally accepted and well-established principals of engineering relevant to the design.” As such, design submittals need to clearly outline the engineering principals utilized in the design and provide peer-reviewed, documented support of the principals used.

**Permit and Submittal** – Construction documents are to include sufficient information and detail to describe adequately the elements of the design necessary for the proper implementation of the smoke control systems. Plan set shall include construction drawings, mechanical drawings, and fire alarm drawings, these plan sets are subject to change if review of smoke control deems it necessary for code compliance.

Rational Analysis supporting the type of smoke control system employed, the methods of their operations, the system supporting them and the methods of construction shall be submitted with plan set.

**Inspection Requirements** – In addition to the ordinary inspection and test requirements for the building, special inspections and testing sufficient to verify the proper commissioning of the smoke control design in its final installed condition are required.

### Fees

Shall apply to; construction and operational permit plan review to include initial inspections and witness testing services performed by PFA and issuance of permits.

Visit our website at: [Poudre Fire Authority](#)

## APPENDIX A

### Plan Review Requirements

- Provide code analysis – see example below

Code Analysis:	
Main Occupancy Type:	I-2, Institutional (Hospital) A-2 and A-3, Assembly (Conference Rooms) B, Business (Administration Offices - Clinic Outpatient) S-2, Storage (Moderate-Hazard Storage)
Tenant Occupancy Type:	B, Business (Administration Offices - Clinic Outpatient) S-2, Storage (Moderate-Hazard Storage)
Number of Stories:	Two
Fire Protection System:	Yes, Fully Fire Sprinklered
Edition of Codes:	2024 IBC, IFB, IMC City of Fort Collins (Poudre FD) Amendments State of Colorado 2017 ANSI 117.1 Guidelines for Accessible & Useable
Type of FA System:	Adding to Existing Fire Alarm Addressable System
FA System Required:	Code-Required
Edition of Standards:	2022 NFPA 72, 2023 NFPA 70 (NEC)
Audible Notification:	Voice Evac - Temporal 3 Pattern / Synchronized
Visual Notification:	Public Mode
Tenant Space Square Footage:	11,042 GSF
Tenant Space Occupant Load:	124

- Provide Scope of Work description on plan set
- Provide space/area for review comments and review stamp on sheet 1 of plan set
- Provide stamp by design professional
  - PE
  - NICET
- Identify on the sheet 1 of plan set
  - Name, address of project
  - Name, address of contractor/installer
  - Name, address of AHJ
    - Poudre Fire Authority – 102 Remington St, Fort Collins, CO 80524
- Provide certifications
  - State of Colorado – DFPC
  - Manufacture certifications